

# **ROTEL** *hifi*

---

STEREO CASSETTE TAPE DECK

# **RD-945AX**

---

# **TECHNICAL MANUAL**

## **TABLE OF CONTENTS**

Specifications.....	1
Chassis Layout.....	1
Adjustment.....	2
PC Board Ass'y Parts List.....	4
Printed Circuit Boards.....	7
Wiring Diagram.....	9
Schematic Diagram.....	10
Disassembly Diagram.....	12

**THE ROTEL CO., LTD.**

1-36-8, OHOKAYAMA, MEGURO-KU, TOKYO 152, JAPAN

**ROTEL ELECTRONICS CO., LTD.**

3F-2, NO.35, FU HSING NORTH ROAD, TAIPEI, TAIWAN, REPUBLIC OF CHINA

MN20001925

# Specifications

RD-945AX

Heads: Rec/ Play.....Permalloy core  
 Erase.....Ferrite core  
 Track.....4-track / 2-channel  
 Tape Speed.....4.8 cm / sec  
 Motor.....Electric Governor  
 Wow and Flutter.....0.2 % (DIN) 0.06 % (WRMS)  
 Distortion (REC/PB, 400 Hz).....2 % (METAL)  
 Frequency Response (-20 dB):  
 Normal, LH.....30 to 15,000 Hz +/-3 dB  
 Special.....30 to 16,000 Hz +/-3 dB  
 Metal.....30 to 17,000 Hz +/-3 dB  
 Signal-to-Noise Ratio (WTD. 0 dB = 710 mV, Chromium):  
 Dolby NR in.....64 dB (B Type)  
 73 dB (C Type)  
 Dolby NR out.....55 dB  
 Input Sensitivity/ Impedance:  
 LINE.....60 mV/ 33 kohms  
 Output Level/ Impedance:  
 LINE.....710 mV/ 1.5 kohms  
 Fast Wind Time (C-60).....80 seconds

Tape Selector	BIAS	EQUALIZER
Normal, LH.....	100 %	120 uS
Special.....	150 %	70 uS
Metal.....	220 %	70 uS

## MISCELLANEOUS

Power Requirement.....120 V/ 60 Hz, 220 V/ 50 Hz,  
 240 V/ 50 Hz (depending on destinations)  
 Power Consumption.....30 watts  
 Dimension (overall).....440 (W) x 121 (H) x 286 (D) mm  
 17-3/8" x 4-13/16" x 11-1/4"  
 Weight (net).....5.6 Kg / 12.32 lbs

- Specifications and design subject to possible modification without notice.
- Dolby noise reduction and HX PRO headroom extension manufactured under license from Dolby Laboratories Licensing Corporation. HX PRO originated by Bang and Olufsen. "Dolby", the double-D symbol, and "HX PRO" are trademarks of Dolby Laboratories Licensing Corporation.

# Chassis Layout

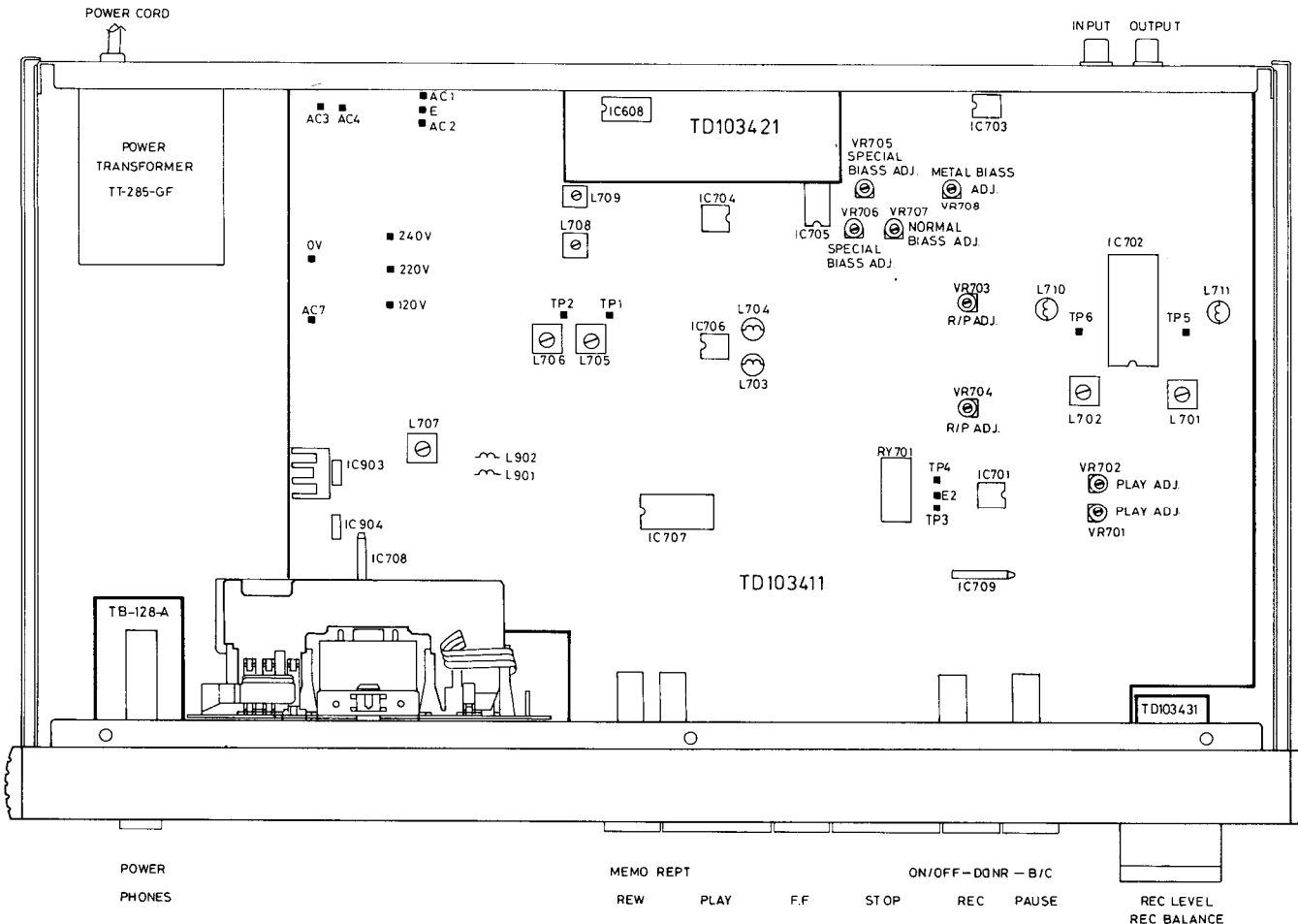

# Playback System Adjustment

Instruments: Oscilloscope, AC VTVM, Frequency Counter and Test Tape.  
 Conditions : Oscilloscope, AC VTVM and Frequency Counter---LINE OUT  
 Dolby NR---OFF

Adjustment Item	Test Tape	Adjust	Adjust for
Azimuth	MTT-114N	REC / PB Head screw	Obtain largest wave form on Oscilloscope for both channels.
Dolby Level	MTT-150	VR701 VR702	AC VTVM reads 245mV at TP5, TP6.
Playback EQ Check	TCC-284N	Output level difference between 1 kHz and 10 kHz signal is within +/- 3.0dB.	
Tape Speed Deflection Check / Tape Speed Adjust	TCC-112	Check that allowable margin of deflecting at middle of or at the end of winding is in the range of +2% -1% (at 3,000 Hz allowable margin of deflection of speed is 3,060-2,970) If Tape Speed deflection surpasses the above range adjust speed of Motor.	

# Recording System Adjustment

Instruments: Oscilloscope, Signal Generator, AC VTVM and Blank Tape  
 Conditions : Dolby NR---OFF REC Level---Maximum

Adjustment Item	Coupling	Tape Selector	Adjust	Adjust for
Bias Carrier	Oscilloscope---point TP1, TP2	METAL	L705 (L-CH) L706 (R-CH)	Obtain Min. deflection on the Oscilloscope
19 kHz Filter	S.G.(400Hz 0dB)--LINE IN /LINE OUT---700mV Changed S.G. to 19kHz Dolby NR---OFF	NORNAL	L701 (L-CH) L702 (R-CH)	AC VTVM reads 30 dB (Minimum)
Bias Voltage	Oscilloscope---point TP3, TP4	METAL	VR708	AC VTVM reads 9.5mV
		SPECIAL	VR705(L-CH) VR706(R-CH)	AC VTVM reads 6.5mV
		NORMAL	VR707	AC VTVM reads 4.0mV

# REC / PB System Adjustment

Instruments: Signal Generator, H.D.Analyzer and Blank Tape.

Conditions : Dolby NR---OFF      REC Level---Maximum

PLAY, REC, PAUSE---ON

Blank Tape : METAL---AC712, SPECIAL---AC513, NORMAL---AC224

Adjustment	Conditions	Adjust	Adjust for
REC / PB Output Level	S.G. (400Hz 0dB) LINE IN / LINE OUT---700mV Push PLAY Button and playback it again	VR703(L-CH) VR704(R-CH)	Recording and Playback level difference must be within +/- 1dB
Distortion Check	S.G. (400Hz 0dB) LINE IN / LINE OUT---700mV H.D.Analyzer--LINE OUT Push PLAY Button and playback it again	Check that distortion is within following range. a.METAL Tape----- under 2.5% b.SPECIAL Tape----- under 2.0% c.NORMAL Tape----- under 1.5%	
	If the distortion factor exceeds the above, recheck Bias Voltage Adjustment.		
Frequency Response Check	METAL Tape insert it	VR708	30Hz--17kHz..+/-3dB
	SPECIAL Tape insert it	VR706	30Hz--16kHz..+/-3dB
	NORMAL Tape insert it	VR707	30Hz--16kHz..+/-3dB

# Parts List

NOTE: THE COMPONENTS IDENTIFIED BY  $\Delta$  MARK ARE FOR SAFETY. REPLACE ONLY WITH ORIGINAL PARTS. DO NOT SUBSTITUTE.

SYMBOL	PARTS NO.	DESCRIPTION
	TD103411	P.C.B. ASSEMBLY
R601	RM51001816	R, METAL 1K 1/4W F
R602	RM52212811	R, METAL 22.1K 1/4W F
R603	RM54751816	R, METAL 4.75K 1/4W F
R604	RM54752810	R, METAL 47.5K 1/4W F
R605-608	RM51001816	R, METAL 1K 1/4W F
R609	RM54752810	R, METAL 47.5K 1/4W F
R610	RM24750810	R, METAL 475 1/4W F
R611, 612	RM51001816	R, METAL 1K 1/4W F
R613	RM52212811	R, METAL 22.1K 1/4W F
R614	RM51002810	R, METAL 10K 1/4W F
R615	RM54759815	R, METAL 47.5 1/4W F
R616	RM54751816	R, METAL 4.75K 1/4W F
R617	RM51001816	R, METAL 1K 1/4W F
R618	RM54751816	R, METAL 4.75K 1/4W F
R619	RM53322818	R, METAL 33.2K 1/4W F
R620	RM51001816	R, METAL 1K 1/4W F
R622	RM53329813	R, METAL 33.2 1.4W F
R701, 702	RM51009815	R, METAL 10 1/4W F
R703, 704	RM51003813	R, METAL 100K 1/4W F
R705, 706	RM53321814	R, METAL 3.32K 1/4W F
R707, 708	RM51003813	R, METAL 100K 1/4W F
R709, 710	RM54759815	R, METAL 47.5 1/4W F
R711, 712	RM52211818	R, METAL 2.21K 1/4W F
R713, 714	RM52741819	R, METAL 2.74K 1/4W F
R715, 716	RM52212811	R, METAL 22.1K 1/4W F
R717, 718	RM51001816	R, METAL 1K 1/4W F
R719, 720	RM52213815	R, METAL 221K 1/4W F
R721, 722	RM51002810	R, METAL 10K 1/4W F
R723	RM51502817	R, METAL 15K 1/4W F
R724	RM51002810	R, METAL 10K 1/4W F
R725	RM58251814	R, METAL 8.25K 1/4W F
R726	RM51001816	R, METAL 1K 1/4W F
R727	RM56811816	R, METAL 6.81K 1/4W F
R728	RM51003813	R, METAL 100K 1/4W F
R729	RM25622815	R, METAL 56.2K 1/4W F
R730	RM51001816	R, METAL 1K 1/4W F
R731	RM51503810	R, METAL 150K 1/4W F
R732	RM51002810	R, METAL 10K 1/4W F
R733	RM51001816	R, METAL 1K 1/4W F
R734	RM51000812	R, METAL 100 1/4W F
R735, 736	RM52212811	R, METAL 22.1K 1/4W F
R737	RM51002810	R, METAL 10K 1/4W F
R738	RM51003813	R, METAL 100K 1/4W F
R739	RM56810812	R, METAL 681 1/4W F
R740, 741	RM52211818	R, METAL 2.21K 1/4W F
R742, 743	RM51002810	R, METAL 10K 1/4W F
R744, 745	RM55621813	R, METAL 5.62K 1/4W F
R746, 747	RM51502817	R, METAL 15K 1/4W F
R748, 749	RM51002810	R, METAL 10K 1/4W F
R750	RM51002810	R, METAL 10K 1/4W F
R751, 752	RM55111811	R, METAL 5.11K 1/4W F
R753, 754	RM54320817	R, METAL 432 1/4W F
R755, 756	RM52431818	R, METAL 2.43K 1/4W F
R757, 758	RM56811816	R, METAL 6.81K 1/4W F
R759, 760	RM56810812	R, METAL 681 1/4W F
R762, 763	RM54752810	R, METAL 47.5K 1/4W F
R764, 765	RM52211818	R, METAL 2.21K 1/4W F
R766, 767	RM54753813	R, METAL 475K 1/4W F
R768, 769	RM53321814	R, METAL 3.32K 1/4 W F
R780	RM51502817	R, METAL 15K 1/4W F
R781, 782	RM54752810	R, METAL 47.5K 1/4W F
R783, 784	RM51000812	R, METAL 100 1/4W F
R785	RM51002810	R, METAL 10K 1/4W F
R786	RM56811816	R, METAL 6.81K 1/4W F
R787, 788	RM51003813	R, METAL 100K 1/4W F
R789	RM51502817	R, METAL 15K 1/4W F
R790	RM53322818	R, METAL 33.2K 1/4W F
R791	RM51502817	R, METAL 15K 1/4W F

SYMBOL	PARTS NO.	DESCRIPTION
R792, 793	RM52212811	R, METAL 22.1K 1/4W F
R794, 795	RM54751816	R, METAL 4.75K 1/4W F
R796	RM51003813	R, METAL 100K 1/4W F
R797, 798	RM51001816	R, METAL 1K 1/4W F
R799	RM51003813	R, METAL 100K 1/4W F
R801, 802	RM52212811	R, METAL 22.1K 1/4W F
R803, 804	RM53923814	R, METAL 392K 1/4W F
R805, 806	RM51503810	R, METAL 150K 1/4W F
R807, 808	RM54751816	R, METAL 4.75K 1/4W F
R809, 810	RM56811816	R, METAL 6.81K 1/4W F
R811, 812	RM51001816	R, METAL 1K 1/4W F
R813, 814	RM55621813	R, METAL 56.2 1/4W F
R815, 816	RM58251814	R, METAL 8.25K 1/4W F
R817, 818	RM54752810	R, METAL 47.5K 1/4W F
R819, 820	RM53921817	R, METAL 3.92K 1/4W F
R821, 822	RM51003813	R, METAL 100K 1/4W F
R823, 824	RM51330812	R, METAL 133 1/4W F
R825, 826	RM54752810	R, METAL 47.5K 1/4W F
R827-830	RM52213815	R, METAL 221K 1/4W F
R831, 832	RM52211818	R, METAL 2.21K 1/4W F
R833, 834	RM53321814	R, METAL 3.32K 1/4W F
R835, 836	RM54751816	R, METAL 4.75K 1/4W F
R837, 838	RM55621813	R, METAL 5.62K 1/4W F
R839	RM52210814	R, METAL 221 1/4W F
R840	RM58252818	R, METAL 82.5K 1/4W F
R841	RM51003813	R, METAL 100K 1/4W F
R842-844	RM51002810	R, METAL 10K 1/4W F
R845	RM51001816	R, METAL 1K 1/4W F
R846, 847	RM57501811	R, METAL 7.5K 1/4W F
R848	RM51001816	R, METAL 1K 1/4W F
R849, 850	RM54751816	R, METAL 4.75K 1/4W F
R851, 852	RM54752810	R, METAL 47.5K 1/4W F
R853, 854	RM51001816	R, METAL 1K 1/4W F
R857	RM51001816	R, METAL 1K 1/4W F
R858	RM54752810	R, METAL 47.5K 1/4W F
R859	RM51003813	R, METAL 100K 1/4W F
R860	RM58251814	R, METAL 8.25K 1/4W F
R861	RM51502817	R, METAL 15K 1/4W F
R862	RM21829813	R, METAL 18.2 1/4W F
R863	RM51502817	R, METAL 15K 1/4W F
R864	RM53329813	R, METAL 33.2 1/4W F
R865	RM54751816	R, METAL 4.75K 1/4W F
R866	RM51000812	R, METAL 100 1/4W F
R867	RM54759815	R, METAL 47.5 1/4W F
R868	RM51000812	R, METAL 100 1/4W F
R869	RM55621813	R, METAL 5.62K 1/4W F
R870	RM51002810	R, METAL 10K 1/4W F
R871	RM51000812	R, METAL 100 1/4W F
R872-875	RM55620810	R, METAL 562 1/4W F
R876-878	RM51002810	R, METAL 10K 1/4W F
R880	RM51501813	R, METAL 1.5K 1/4W F
R881	RM51002810	R, METAL 10K 1/4W F
R882, 883	RM51501813	R, METAL 1.5K 1/4W F
R884	RM51002810	R, METAL 10K 1/4W F
R885	RM51501813	R, METAL 1.5K 1/4W F
R886	RM52741819	R, METAL 2.74K 1/4W F
R892	RM51001816	R, METAL 1K 1/4W F
R893	RM51000812	R, METAL 100 1/4W F
R894	RM51002810	R, METAL 10K 1/4W F
R895	RM52212811	R, METAL 22.1K 1/4W F
R896, 897	RM55621813	R, METAL 5.62K 1/4W F
R898, 899	RM51003813	R, METAL 100K 1/4W F
R901	RM23300810	R, METAL 332 1/4W F
R902	RM52210814	R, METAL 221 1/4W F
R905	RM53321814	R, METAL 3.32K 1/4W F
R906, 907	RM53329813	R, METAL 33.2 1/4W F
R910	RM98209122	R, METAL 82 1W
C701, 702	CS44711420	CAP, STYROL 470P 50V

# Parts List

SYMBOL	PARTS NO.	DESCRIPTION
C703,704	CE01005167	CAP,ELEC. 100uF 16V
C705,706	CE02207501	CAP,ELEC. 2.2uF 50V
C707,708	CM03909420	CAP,MYLAR 393 J 50V
C709,710	CM02709423	CAP,MYLAR 273 J 50V
C711,712	CE04707252	CAP,ELEC. 4.7uF 25V
C713	CE01006251	CAP,ELEC. 10uF 25V
C714	CM02209426	CAP,MYLAR 223 J 50V
C715-718	CE04707501	CAP,ELEC. 4.7uF 50V
C719,720	CM03010423	CAP,MYLAR 302 J 50V
C721,722	CC06812439	CAP,CERAMIC 680P 50V
C723,724	CM04710428	CAP,MYLAR 472 J 50V
C725,726	CE01508256	CAP,ELEC. 0.15uF 25V
C727,728	CE04708505	CAP,ELEC. 0.47uF 50V
C729,730	CE02208505	CAP,ELEC. 0.22uF 50V
C731,732	CM06809424	CAP,MYLAR 683 J 50V
C733,734	CM04709426	CAP,MYLAR 473 J 50V
C735,736	CM06810426	CAP,MYLAR 682 J 50V
C737,738	CM01009427	CAP,MYLAR 103 J 50V
C739,740	CM01509424	CAP,MYLAR 153 J 50V
C741,742	CE04707501	CAP,ELEC. 4.7uF 50V
C743,744	CE01006500	CAP,ELEC. 10uF 50V
C745,746	CE01006500	CAP,ELEC. 10uF 50V
C747,748	CM01009427	CAP,MYLAR 103 J 50V
C749,750	CM02208422	CAP,MYLAR 224 J 50V
C751,752	CM01009427	CAP,MYLAR 103. J 50V
C753,754	CC31011435	CAP,CERAMIC 100P 50V
C755,756	CS44711327	CAP,STYROL 470P 250V
C757,758	CS42711324	CAP,STYROL 270P 250V
C759,760	CM01008423	CAP,MYLAR 104 J 50V
C761,762	CS44711420	CAP,STYROL 470P 50V
C763,764	CE04708505	CAP,ELEC. 0.47uF 50V
C765,766	CE04707501	CAP,ELEC. 4.7uF 50V
C767,768	CE01006500	CAP,ELEC. 10uF 50V
C769,770	CM02009425	CAP,MYLAR 203 J 50V
C771	CE01007504	CAP,ELEC. 1uF 50V
C772,773	CM08210426	CAP,MYLAR 822 J 50V
C774	CM01008423	CAP,MYLAR 104 J 50V
C775,776	CS41511327	CAP,STYROL 150P 250V
C777	CM01009427	CAP,MYLAR 103 J 50V
C778	CM01509424	CAP,MYLAR 153 J 50V
C779	CE01007504	CAP,ELEC. 1uF 50V
C780	CN01007507	CAP,NON-POLARIZED 1uF 50V
C781	CP01510420	CAP,P.P 122 J 250V
C782	CE01005167	CAP,ELEC. 100uF 16V
C783	CM01008423	CAP,MYLAR 104 J 50V
C784	CM08210426	CAP,MYLAR 822 J 50V
C785	CE01005106	CAP,ELEC. 100uF 10V
C786	CC01008458	CAP,CERAMIC 0.1uF 50V
C788	CE04707501	CAP,ELEC. 4.7uF 50V
C789,790	CM01810422	CAP,MYLAR 182 J 50V
C901,902	CE04705358	CAP,ELEC. 470uF 35V
C903,904	CE02205255	CAP,ELEC. 220uF 25V
C905	CE03304356	CAP,ELEC. 3300uF 35V
C906	CE02204251	CAP,ELEC. 2200uF 25V
C907	CE04705164	CAP,ELEC. 470uF 16V
C908	CE02205164	CAP,ELEC. 220uF 16V
C909,910	CE01005167	CAP,ELEC. 100uF 16V
C911,912	CE01005167	CAP,ELEC. 100uF 16V
C913,914	CE01005167	CAP,ELEC. 100uF 16V
C915,916	CE01005167	CAP,ELEC. 100uF 16V
C917,918	CE02205164	CAP,ELEC. 220uF 16V
C919,920	CE01005167	CAP,ELEC. 100uF 16V
C921-928	CC01009256	CAP,CERAMIC 0.01uF 250V
C929	CE01005258	CAP,ELEC. 100uF 25V
D701	DD20000272	ZENER DIODE RD-7.5E
D702	DD20000260	ZENER DIODE RD-4.3E
D703	DD80000021	DIODE IN4148
D704-708	DD80000010	DIODE IN4003
D709-719	DD80000021	DIODE IN4148

SYMBOL	PARTS NO.	DESCRIPTION
D720-727	DD80000021	DIODE IN4148
D728-730	DD80000021	DIODE IN4148
D732	DD80000021	DIODE IN4148
D901-910	DD80000010	DIODE IN4003
D913,914	DD20000200	DIODE UZ5.1E
Q701,702	TR30000327	TRANSISTOR 2SC536G
Q703,704	TR30000583	TRANSISTOR 2SC2878 (A,B)
Q705,706	TR30000327	TRANSISTOR 2SC536G
Q707	TR10000126	TRANSISTOR 2SA608K (F,G)
Q708,709	TR30000327	TRANSISTOR 2SC536G
Q712-715	TR30000327	TRANSISTOR 2SC536G
Q716,717	TR10000126	TRANSISTOR 2SA608K (F,G)
Q718-722	TR30000327	TRANSISTOR 2SC536G
Q723-730	TR30000327	TRANSISTOR 2SC536G
Q733,734	TR30000327	TRANSISTOR 2SC536G
Q735,736	TR10000126	TRANSISTOR 2SA608K (F,G)
Q737-739	TR30000327	TRANSISTOR 2SC536G
Q740	TR10000126	TRANSISTOR 2SA608K (F,G)
Q741	TR30000327	TRANSISTOR 2SC536G
Q742-744	TR30000327	TRANSISTOR 2SC536G
Q745	TR10000126	TRANSISTOR 2SA608K (F,G)
Q746	TR30000080	TRANSISTOR 2SD863 (E,F)
Q747-749	TR30000327	TRANSISTOR 2SC536G
Q750,751	TR30000583	TRANSISTOR 2SC2878 (A,B)
Q752	TR30000327	TRANSISTOR 2SC536G
IC701	IC00001693	IC NE5532AN
IC702	IC00001980	IC CX20187
IC703	IC00001474	IC NJM4556D
IC704	IC00002235	IC TL-072CP
IC705	IC00002545	IC BA-10324
IC706	IC00001693	IC NE5532AN
IC707	IC00002508	IC TC9312AN-058
IC708	IC00002491	IC TA7291P
IC709	IC00001085	IC TA7341D
IC901	IC00001991	IC NJM79M12
IC902	IC00000974	IC NJM78M12
IC903	IC00001930	IC NJM7812
IC904	IC00000615	IC NJM78M05
RY701	LY00000253	RELAY RY-12W-OH-KJ !
L701,702	LC23700000	COIL,MPX FILTER TRL-370
L703,704	LM00000371	MICRO INDUCTOR 3.9mH RTL-324
L705,706	LC31040107	COIL,TRAP RLV104A00T
L707	LC23670006	COIL,OSC TRL-367
L708,709	LC31260004	COIL,HXPRO RLV126A00T
L710,711	LM00000449	MICRO INDUCTOR 19mH TRL-350
L901,902	LM00000012	MICRO INDUCTOR 470uH TRL-237
VR701,702	RV20000478	R,SEMI-FIXED RH0615C47300
VR703,704	RV20000478	R,SEMI-FIXED RH0615C47300
VR705-707	RV20000442	R,SEMI-FIXED RH0615C22300
VR708	RV20000430	R,SEMI-FIXED RH0615C10300
S1,S2	SH11000380	1 KEY PUSH 4TR-2819
S5,S6	SH11000380	1 KEY PUSH 4TR-2819
	TD103421	P.C.B ASSEMBLY
R650	RM51002810	R,METAL 10K 1/4W F
R651	RM51000812	R,METAL 100 1/4W F
R652	RM54752810	R,METAL 47.5K 1/4W F
R653,654	RM51002810	R,METAL 10K 1/4W F
R655	RM54752810	R,METAL 47.5K 1/4W F
R656	RM51002810	R,METAL 10K 1/4W F
R657,658	RM51000812	R,METAL 100 1/4W F
R659	RM51002810	R,METAL 10K 1/4W F
R660	RM54751816	R,METAL 4.75K 1/4W F
R661,662	RM54752810	R,METAL 47.5K 1/4W F
R663	RM54753813	R,METAL 475K 1/4W F
R664	RM51001816	R,METAL 1K 1/4W F
R665	RM51003813	R,METAL 100K 1/4W F
R666	RM54751816	R,METAL 4.75K 1/4W F
C610,611	CE01006160	CAP,ELEC. 10uF 16V

SYMBOL	PARTS NO.	DESCRIPTION
C612	CE02206259	CAP,ELEC. 22uF 25V
Q606-610	TR30000327	TRANSISTOR 2SC536G
Q611	TR10000126	TRANSISTOR 2SA608K (F,G)
Q612	TR30000327	TRANSISTOR 2SC536G
Q613	TR10000126	TRANSISTOR 2SA608K (F,G)
IC608	IC00002363	IC TC4011BP
D610-620	DD10000100	DIODE IN4148
	TD103431	P.C.B ASSEMBLY
VR604	RV10001553	R,VARIABLE 4TR-2775 50Kx2
	TD103441	P.C.B ASSEMBLY
VR603	RV10001589	R,VARIABLE 4TR-2821 250KW
R641,642	RM52211818	R,METAL 2.21K 1/4W F
	TD104217	P.C.B ASSEMBLY
R673,674	RM21002815	R,METAL 10K 1/4W F
R675,676	RM23321812	R,METAL 3.32K 1/4W F
R677,678	RM26042818	R,METAL 60.4K 1/4W F
C621-624	CE01006251	CAP,ELEC. 10uF 25V
IC611,612	IC00001954	IC LB1408
D621-628	DD40000101	LED LN324G
D629-639	DD40000095	LED LN224R
D640	DD40000101	LED LN324G
D641	DD40000095	LED LN224R
D642	DD40000101	LED LN324G
S601-606	SH60000240	KSY BOARD SW 4TR-2343
	TD104227	P.C.B ASSEMBLY
	JH00000147	HEAD PHONE JACK C-3921#3
	TB-128-A	P.C.B ASSEMBLY
S001	SH40000120	POWER SW C-3600B-T ⚠
C001	CK00000035	SPARK KILLER DE7150F472M ⚠
		OTHERS
	AB00000640	BOTTOM BOARD 4TQN-12B
	AF40000288	FRONT CHASSIS 2TQK-3#1
	AR40000262	PRINTED REAR CHASSIS TRP-599
	AS01000294	SIDE CHASSIS 3TQL-1
	DC00000499	COUNTER BELT 4TWD-12C#8 60F
	DC00000694	CASSETTE DECK ASS'Y CMAY5Z334C
	PT28507102	POWER TRANSFORMER TT-285GF ⚠
	DC00000736	TAPE COUNTER T3SR100-070-803
	FT00000229	PLASTIC FOOT 4TSH-19#2 50Fx14H
	SP10006442	EJECT SUPPORT 4TQK-10
	SP10006545	TAPE COUNTER SUPPORT 4TQM-5
	CD00000218	AC CORD SPT-2 AWG#18 4TR-670#4 ! (U,C,A,J)
	CD00000048	AC POWER CORD 4TR-1037 ⚠ (H,E,K2)
	CD00000085	AC POWER CORD C-2504A ⚠ (K1)
	CD00000292	AC POWER CORD 4TR-2631#1 H05VV-F ⚠ (D)
	CD00000115	AC POWER CORD C-3763-T ⚠ (G)
	NP00001949	NAME STICKER AC120V 4TR-2828#1 TNP-382
	NP00001974	NAME STICKER AC120V-C 4TR-2828#4 TNP-385
	NP00001962	NAME STICKER AC240V 4TR-2828#3 TNP-384

SYMBOL	PARTS NO.	DESCRIPTION
	NP00001998	NAME STICKER AC230V 4TR-2828#5 TNP-389
	NP00002012	NAME STICKER AC100V 4TR-2828#6 TNP-391
	NP00001950	NAME STICKER AC220V 4TR-2828#2 TNP-383
	SC00000131	AC CORD STOPPER SR-5N-4 ⚠ (K1,A)
	SC00000039	AC CORD STOPPER SR-6W-1 ⚠ (D)
	SC00000027	AC CORD STOPPER SR-4N-4 ⚠
	AA40000445	FRONT PANEL 2TQK-1#3 TFP-633
	AW00000551	ACRYLIC DOOR PLATE 2TQK-17
	AW00000563	PANEL WINDOW 4TQK-6#2
	BU00001145	POWER RING W/LED 4TQF-13 14x14
	BU00001157	PUSH BUTTON RING 4TQF-14 5x10
	BU00001169	KNOB RING 4TQF-17 39F
	BU00001200	EJECT BUTTON RING 4TQK-16
	BU00001212	PUSH BUTTON RING PR4-09A00T 5x20
	KB20002681	POWER BUTTON 4TQF-15 14x14
	KB20002693	PUSH BUTTON 4TQF-16 5x10
	KB20002711	TACT BUTTON 6 KEY 3TQK-8
	KB20002759	PUSH BUTTON PR4-13A00T 5x20
	OM10001284	ORNAMENTAL SIDE BOARD 4TR-2797#3 H=109MM
	OM10001326	ALUMIN. DOOR 4TQK-5 TFP-637
	DD40000095	LED SEL1124R/LN224R
	OM70000065	PUSH BUTTON CONNECTOR 4TTL-15
	SN00000179	BUTTON SPRING 4TR-1988A#2
	AU00001249	TOP COVER POLY 3TUV-6#8
	KB10001722	KNOB 4TQG-18 13F
	KB10001760	KNOB 4TQG-6 33F
	KB20002735	EJECT BUTTON 4TQK-18
	OM10001314	LED ORNAMENTAL PLATE 4TQM-3
	FE00000067	FELT 4TR-1083B#1 22F
	FE00000079	FELT 4TR-1083B#3 46F
	SP10006557	EJECT CONNECTOR 4TQK-21
	SR00000882	UPPER COVER SPACER 4TR-2418
	MN10002800	OWNER'S MANUAL RD-945AX
	PL00001075	STYROL SIDE MOULDING 3TTW-14#2 TZ-172-1

# Printed Circuit Boards

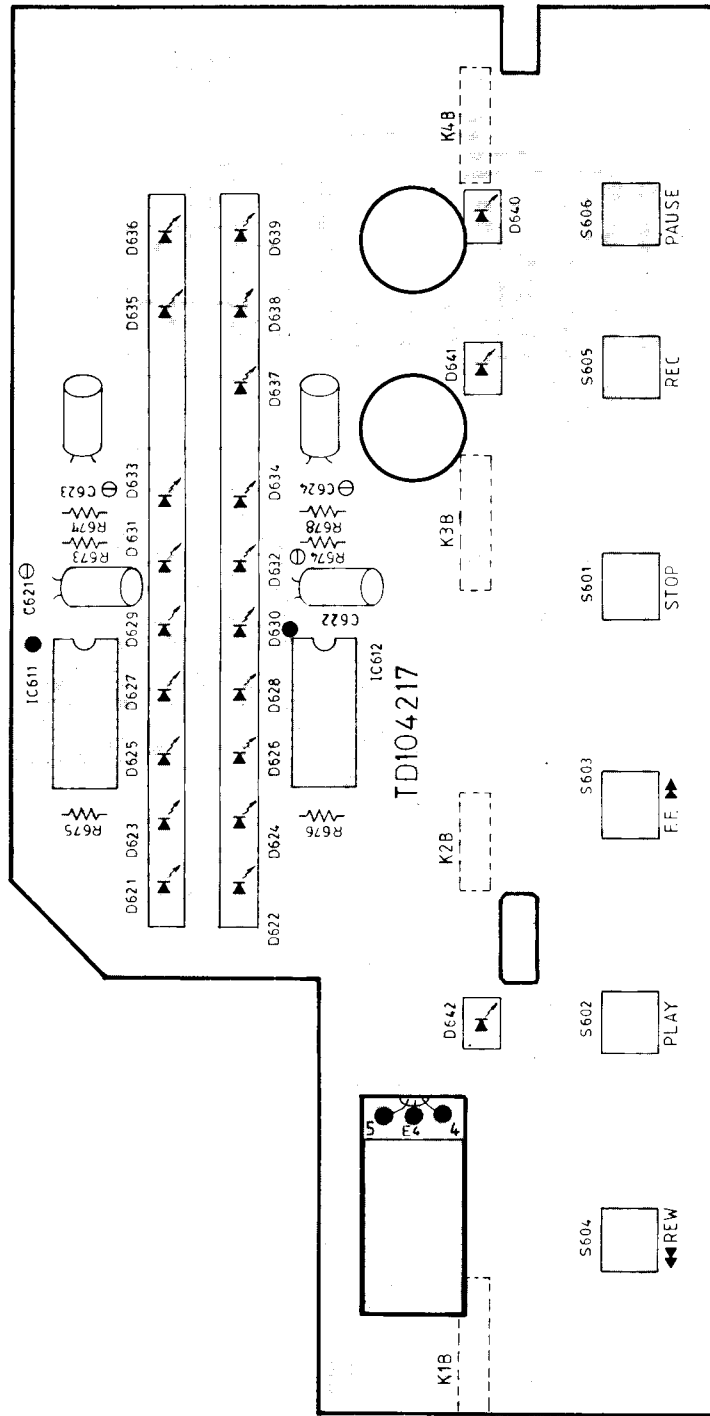
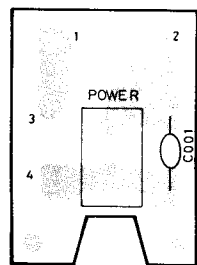





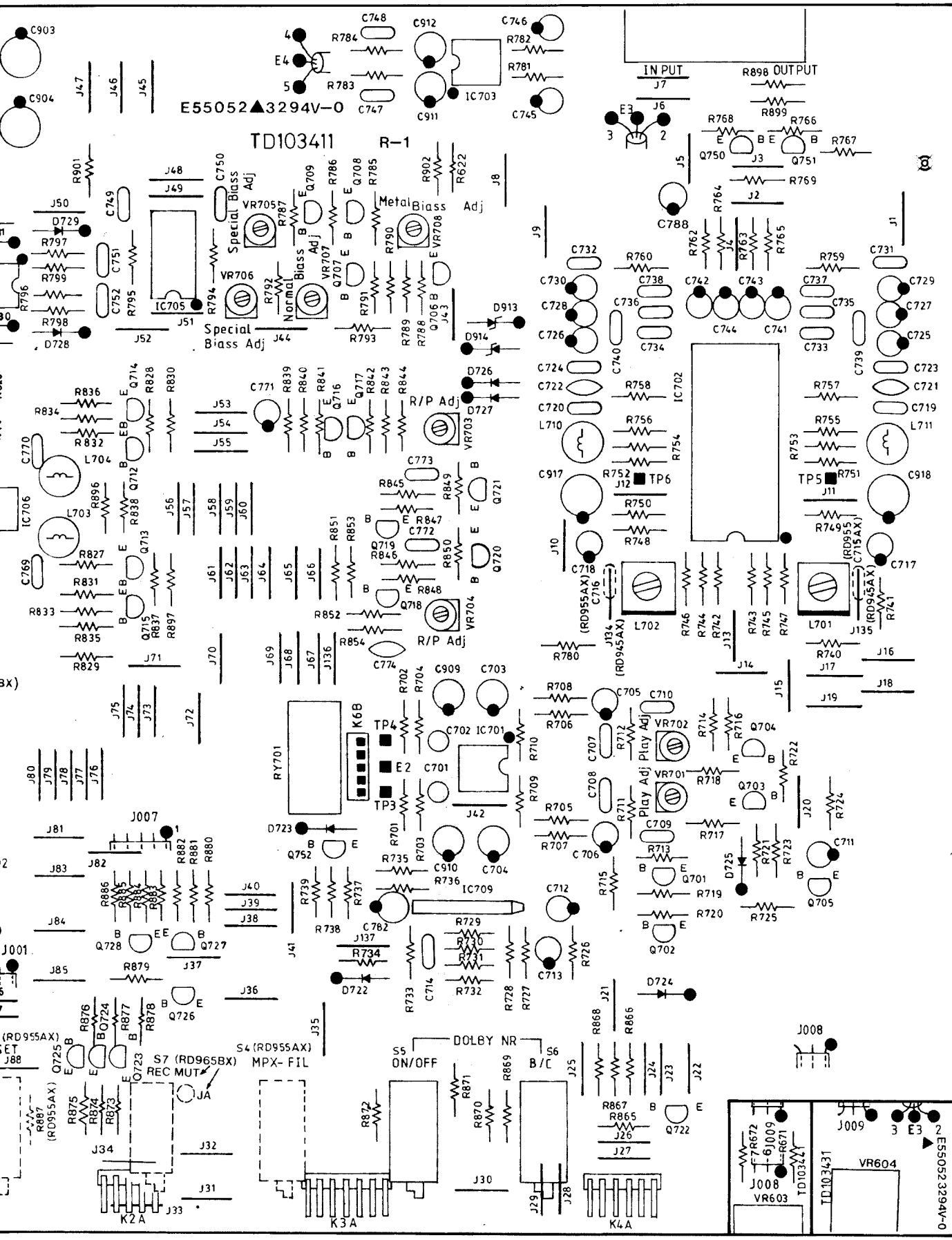

E55052▲3294V-0

TD103411

R-1

INPUT J7

R898 OUTPUT

(X)

(BX)

2

J001

(RD955AX)

(RD955AX)

E550523294V-0

# Schematic Diagram

( NOTE: PARTS AND CIRCUIT SUBJECT TO CHANGES FOR IMPROVEMENT WITHOUT PRIOR

## SCHEMATIC DIAGRAM RD-945AX

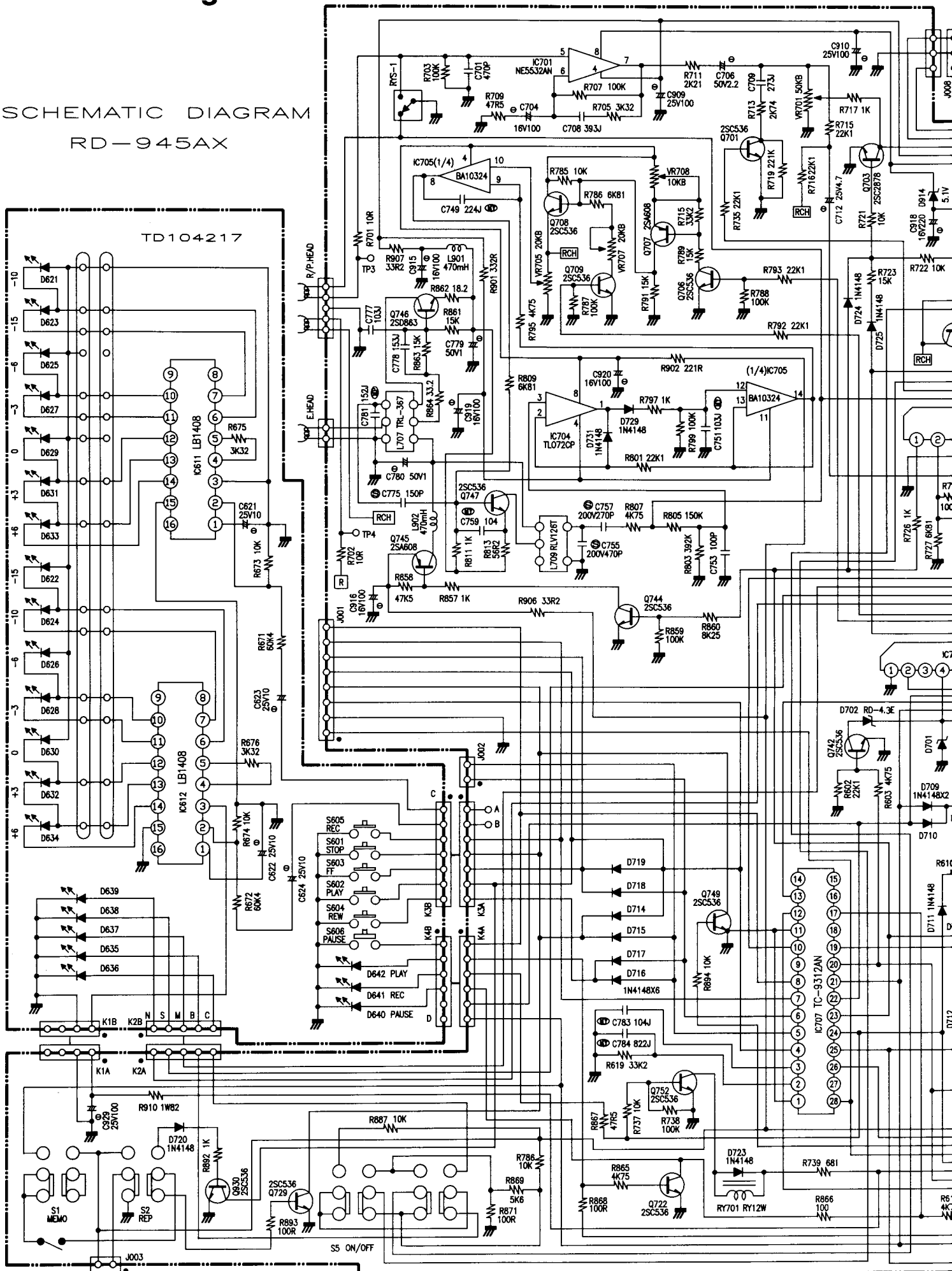

MENT WITHOUT PRIOR NOTICE.)

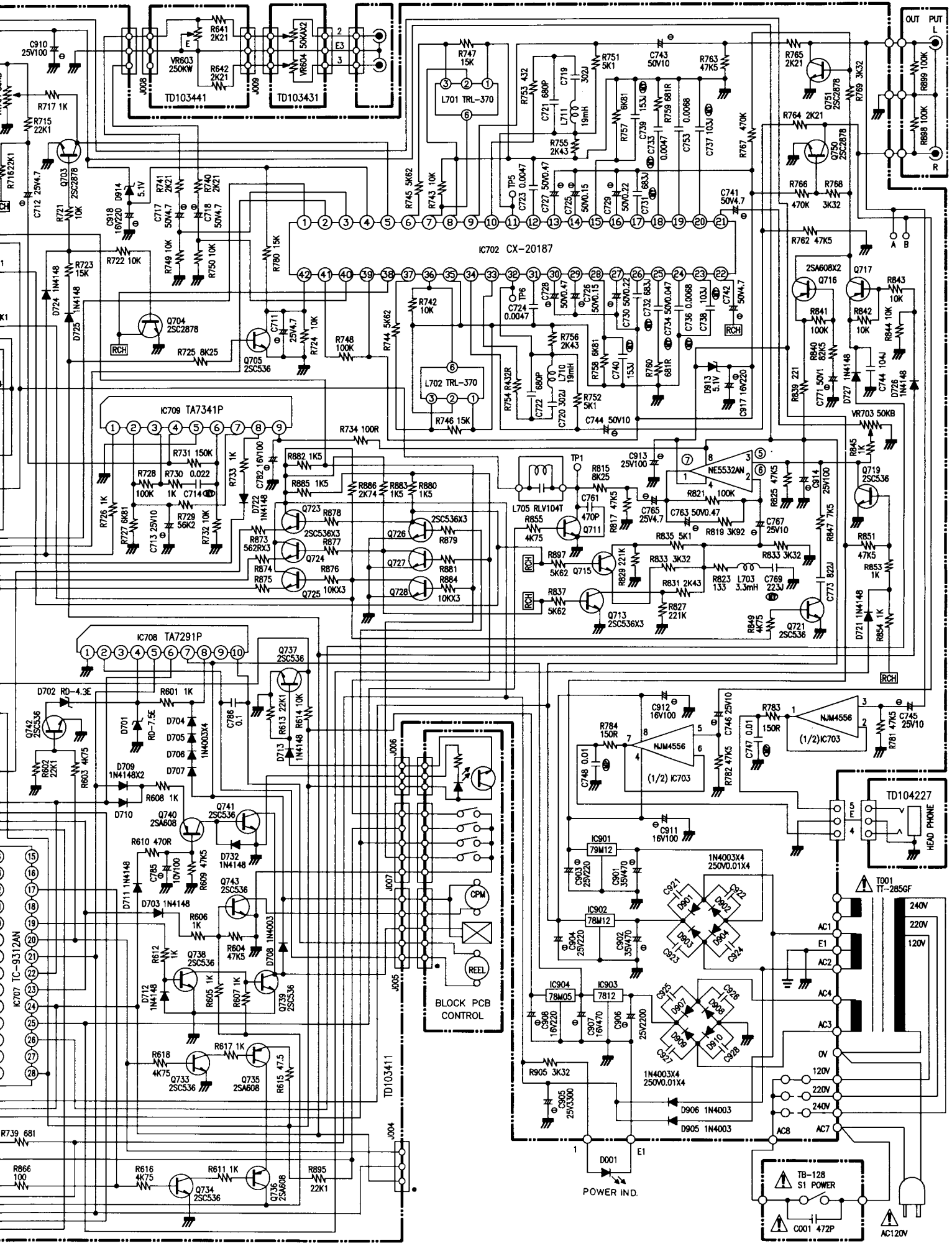

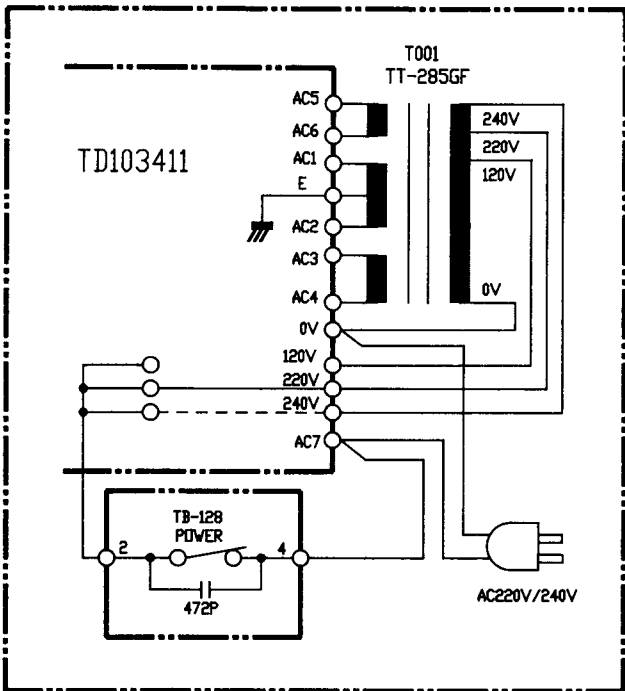
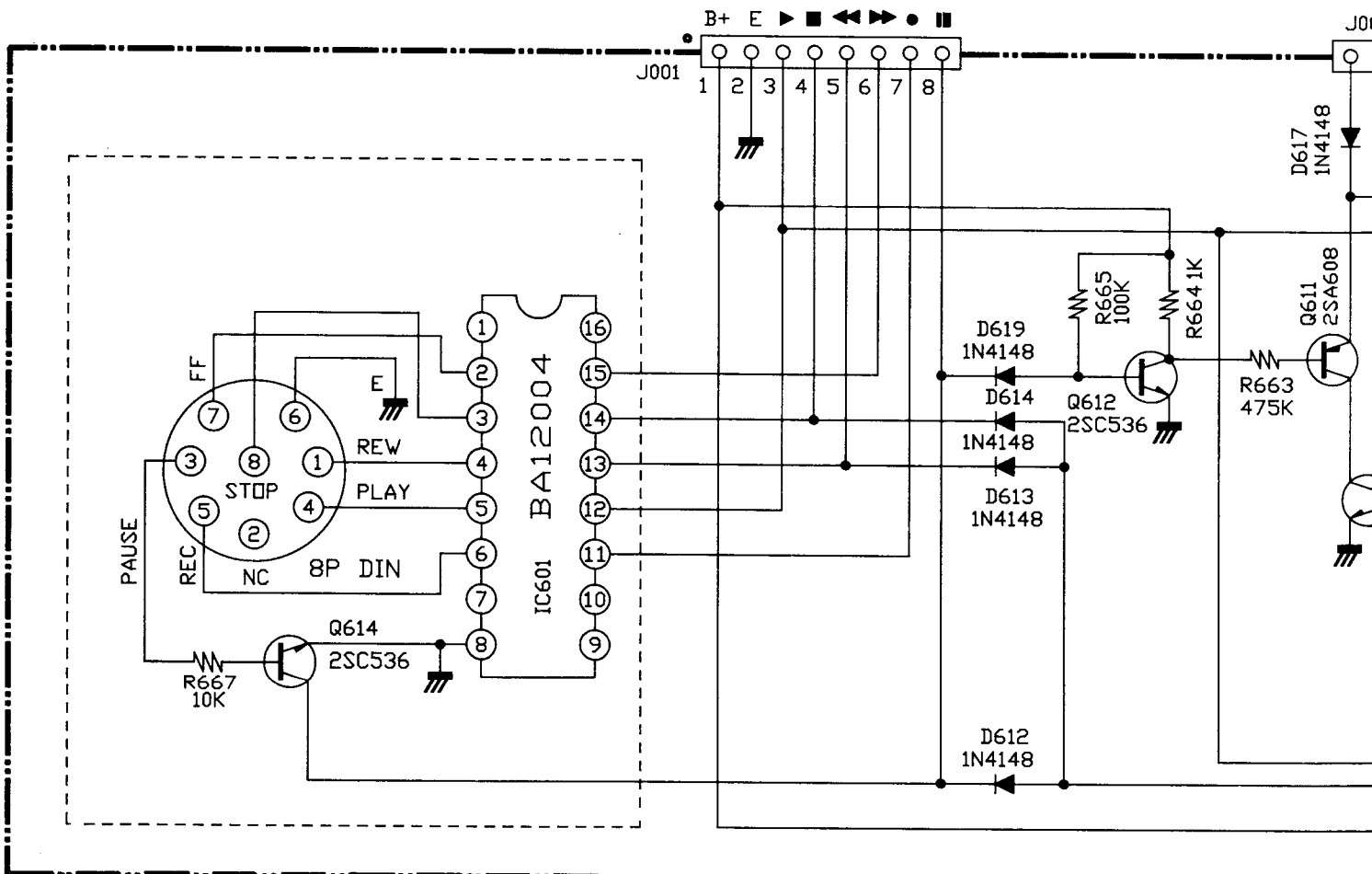

**INSTRUCTION FOR SERVICING PERSONNEL:**

- 1). USE ONLY REPLACEMENT PARTS THAT HAVE THE CRITICAL CHARACTERISTICS RECOMMENDED BY MANUFACTURER.
- 2). MAKE LEAKAGE-CURRENT OR RESISTANCE MEASUREMENTS TO DETERMINE THAT EXPOSED PARTS ARE ACCEPTABLY INSULATED FROM THE AC SUPPLY CIRCUIT BEFORE RETURNING THE UNIT TO THE CUSTOMER.

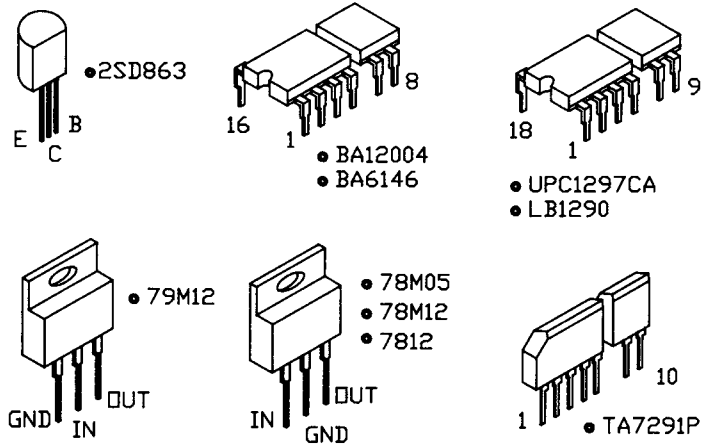

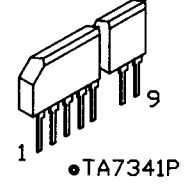
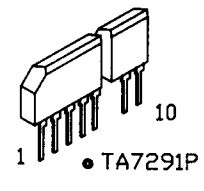
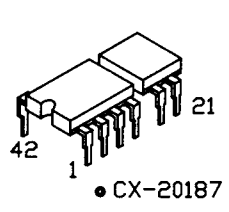
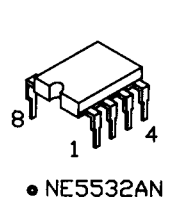
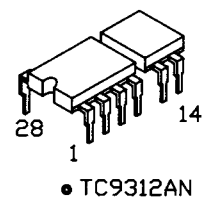
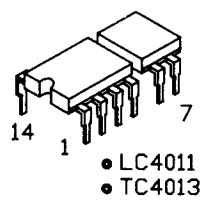
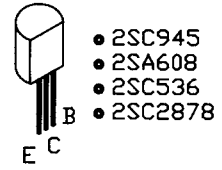
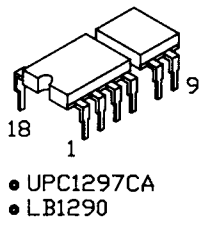
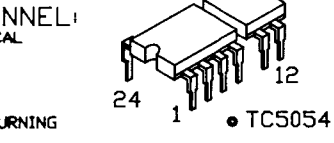
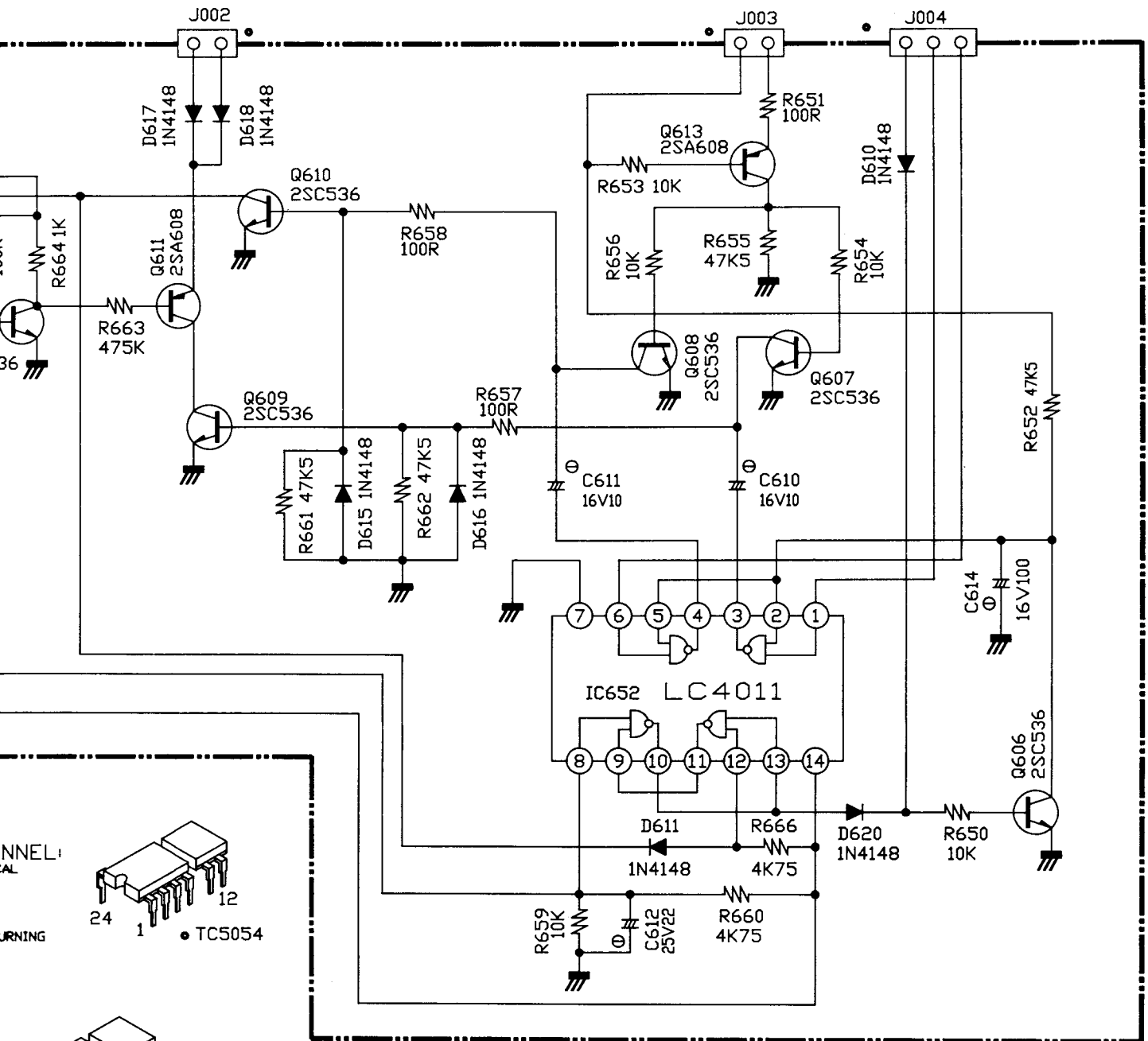

# Disassembly Diagram

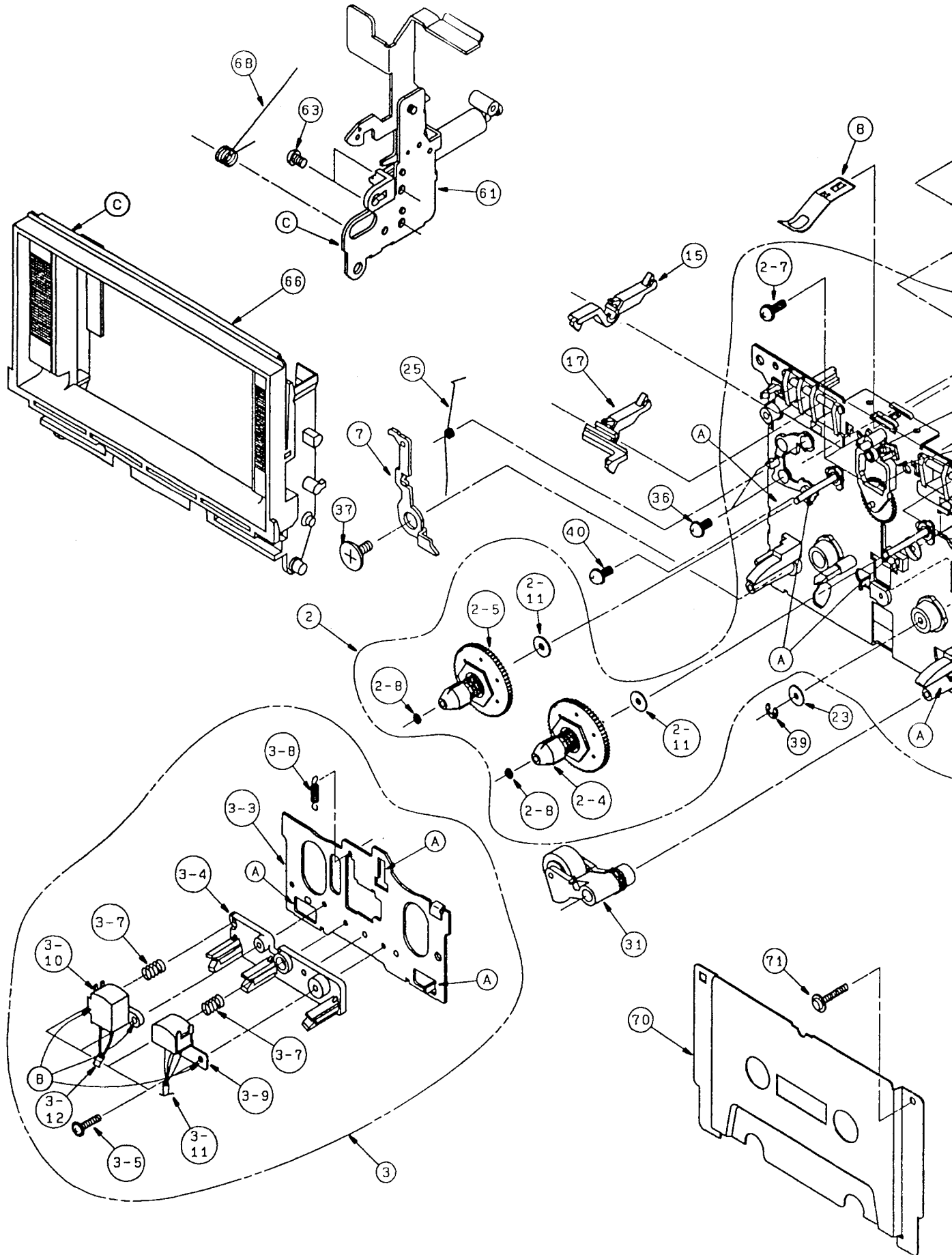

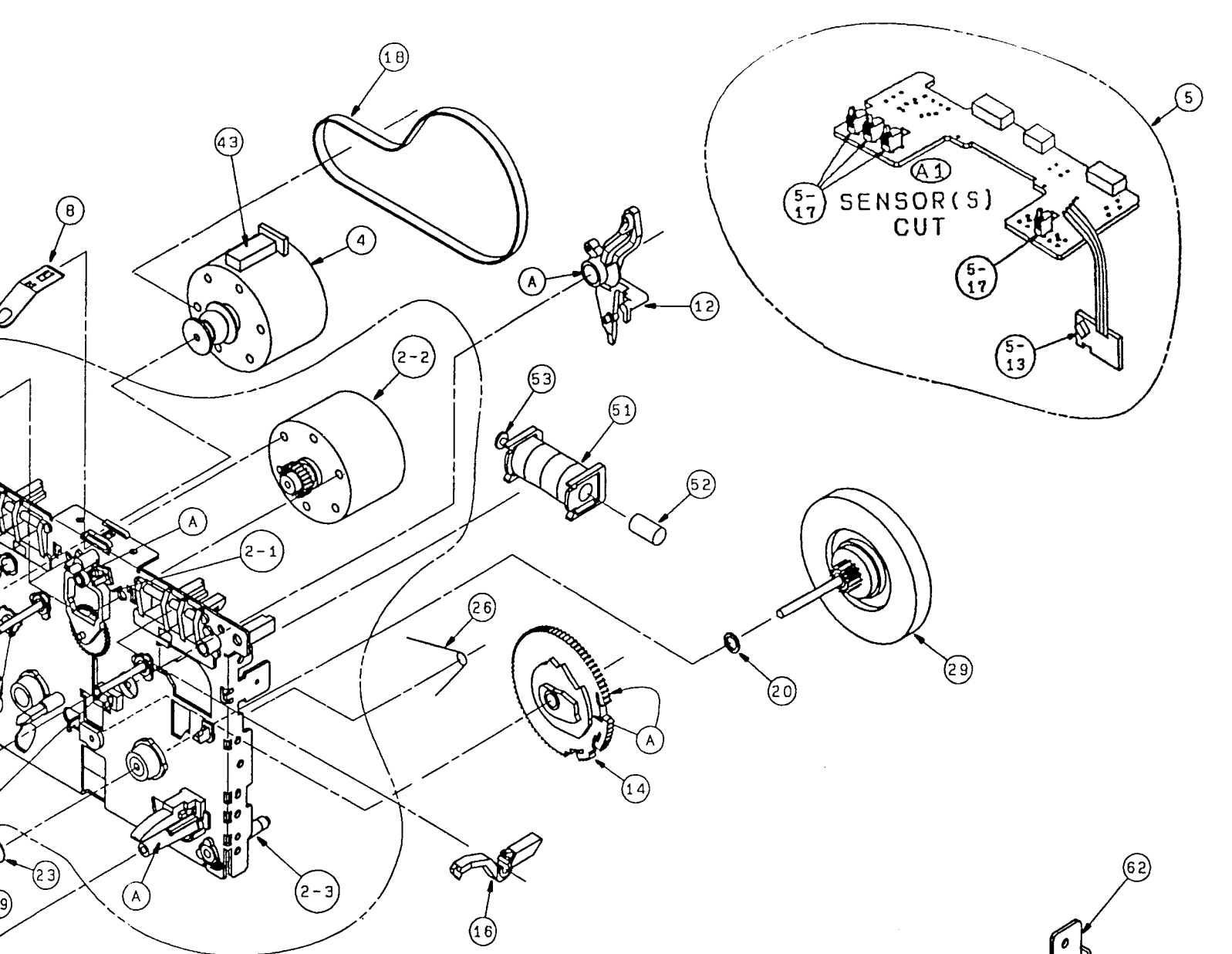

SYMBOL	PARTS NO.	DESCRIPTION
2	F511-422	BLOCK CHASSIS
2-1	F517-049	BLOCK IDLER
2-2	F564-280	BLOCK MOTOR REEL
2-3	F612-156	BLOCK BASE CHASSIS
2-4	F623-037	BLOCK BASE REEL
2-5	F623-127	BLOCK BASE REEL
2-7	FG156-11A	SCREW 2.6x6.4 ZN
2-8	FJ111-17	WASHER 1.7x0.25
2-11	UJ12V-11	POLYSLIDER 2.1x0.25
3	F513-632	BLOCK PLATE HEAD
3-3	FC52E-46	BASE HEAD
3-4	FD45T-16	SPACER HEAD
3-7	FK21U-11	SPRING AZIMUTH
3-8	FK26N-14	SPRING BASE HEAD
3-9	FU16S-11	R/P HEAD (HAYEH4405A)
3-10	FU192-11	E HEAD
3-11	WH51U-04	WIRE CONNECTOR (R/P)
3-12	WH46W-04	WIRE CONNECTOR (E)
4	F525-269	BLOCK MOTOR MAIN
5	F567-255	BLOCK PCB CONTROL
5-13	AW13F-00	SENSOR (SPI-335-34-FG)
5-17	UE16E-11	PUSH SWITCH
7	FC39S-33	ARM INTERLOCK (OW)
8	FC52H-13	SPRING CASSETTE PUSHING
12	FD45G-13	ARM PLAY
14	FD45B-15	GEAR CAM
15	FD44T-14	LEVER (REC SW)
16	FD44Y-12	LEVER (PACK SW)
17	FD44V-12	LEVER (METAL SW)
18	FF17W-31	BELT MAIN
		20 FJ111-30 POLYSLIDER 2.6x0.25
		23 FJ111-14 POLYSLIDER 2.6x0.5
		25 FK28M-16 SPRING INTERLOCK (L)
		26 FK28R-11 SPRING SRIDE
		29 FR22D-11 ASSY FLYWHEEL
		31 FR20L-22 ASSY PINCH ROLLER (R)
		36 FG114-14 SCREW 2.6x5 ZN
		37 UG15S-11A SCREW
		39 UG13U-15 E-RING
		40 UG12H-16 SCREW 3.0x8 ZN
		43 FF17C-12 CUSHION HOLD
		51 F765-263 BLOCK SOLENOID
		52 FL39H-12A IRON CORE
		53 FL39K-12 PLUNGER
		61 FC52R-11 BRACKET DAMRER (L)
		62 F573-096 PLATE HOLD BLK
		63 KG194-28 SCREW 2.6x4 ZN
		66 FD29U-11 DOOR FRAME
		70 F684-053 BLOCK DRESSING
		71 UG12T-11 SCREW

